

版本 REV.	日期 DATE	ECN NO.	变更内容 DESCRIPTION	制图 DRAWN

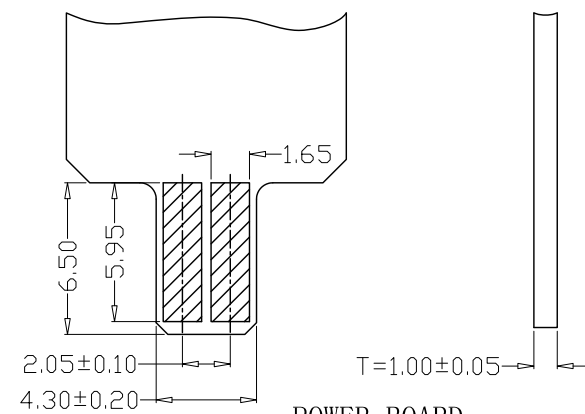

POWER BOARD
PCB LAYOUT

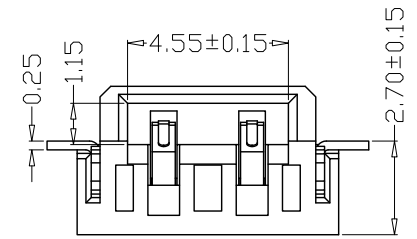
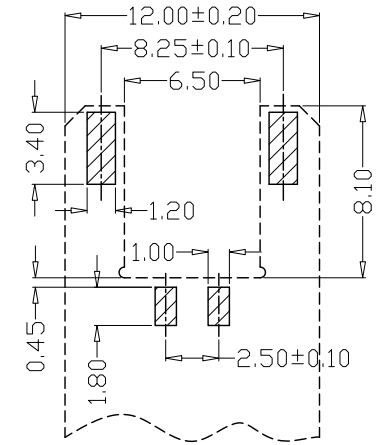

PCB LAYOUT

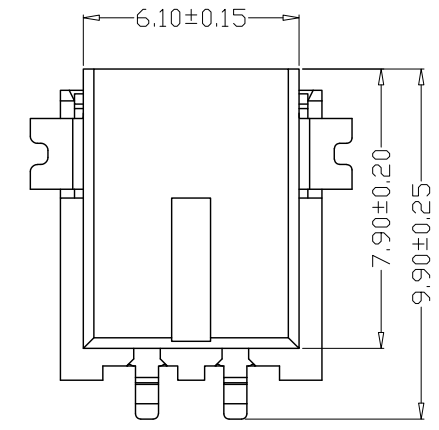
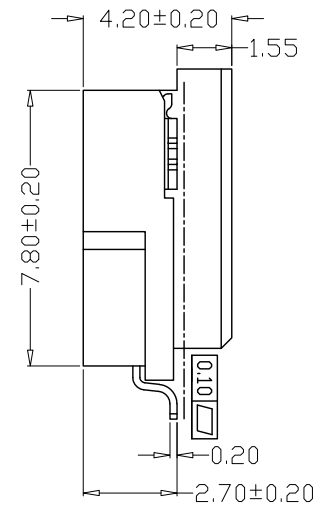
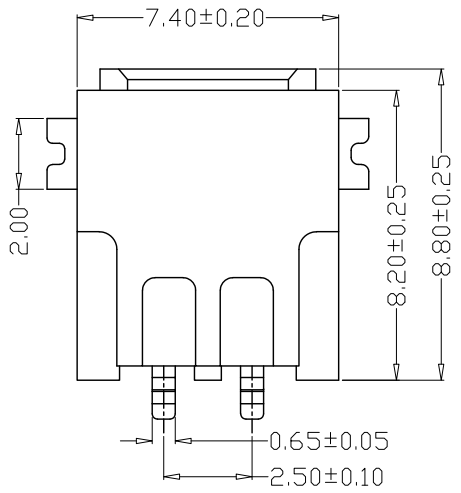

SPECIFICATIONS

- 1、Current Rating: 3A AC, DC
- 2、Voltage Rating: 250V AC, DC
- 3、Temperatuer Range: -25°C~+85°C
- 4、Contact Resistance: 20mΩ Max
- 5、Insulation Resistance: 1000MΩ Min
- 6、Withstanding Voltang: 1000V AC/minute
- 7、Material:Wafer LCP,UL94V-0
PIN Phosphoric bronzes Tin-plated
Solder tad Brass Tin-plated

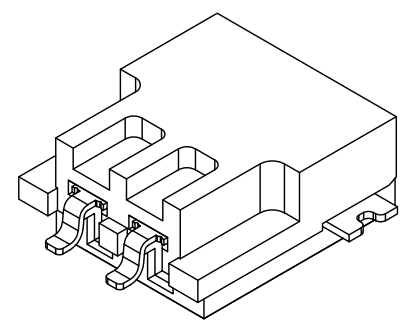
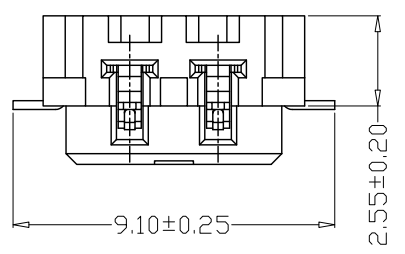

GENERAL TOLERANCE		制图 Mapping	张迎春 2022、09、17	料号 PART NO.	B25003-2AWB	版本 REV.	A
X±0.25	X°±2°	审核 Audit	钱岳生 2022、09、17	品名 TITLE	25017沉板式卧贴 WAFER SMT TYPE	页次 SHEET	1/1
.X±0.25	.X°±1°	核准 Approved	张名 2022、09、18	客户料号 CUTM. NO.			
.XX±0.15	.XX°±0.5°	单位 Units	mm	比例 SCALE			
.XXX±0.10	.XXX°±0.5°			乐清市宏一电子有限公司 Yueqing HongYi Electronics Co., Ltd			